

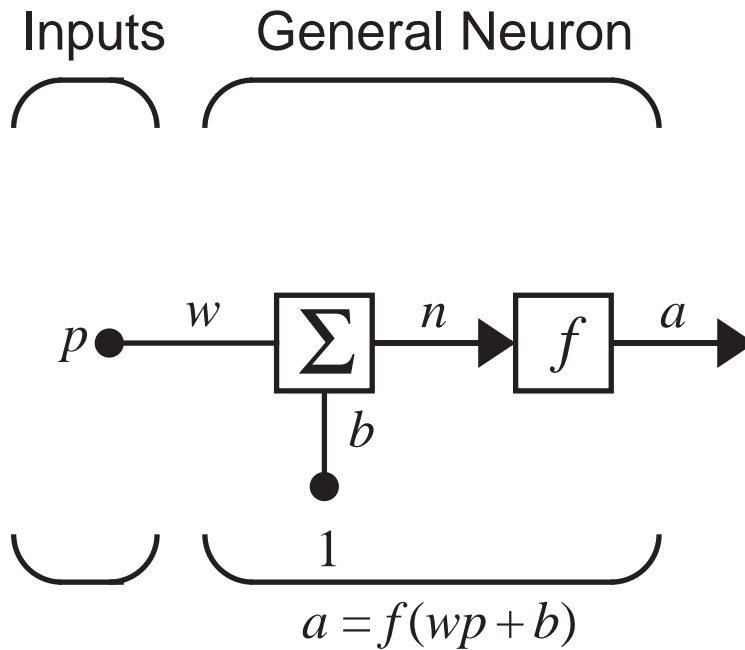

Neuron Model and Network Architectures

Single-Input Neuron

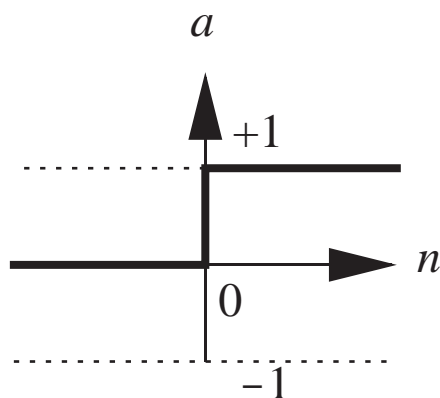



$$a = \text{hardlim}(n)$$

Hard Limit Transfer Function

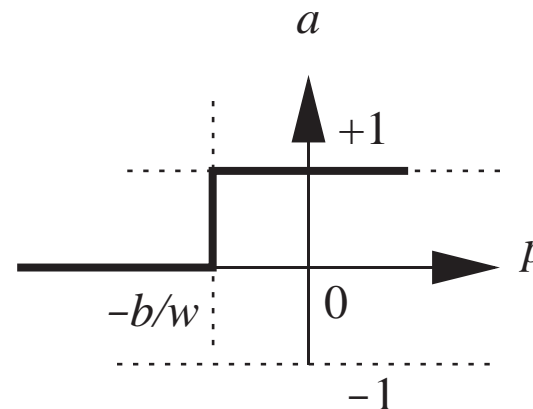

$$a = \text{hardlim}(wp + b)$$

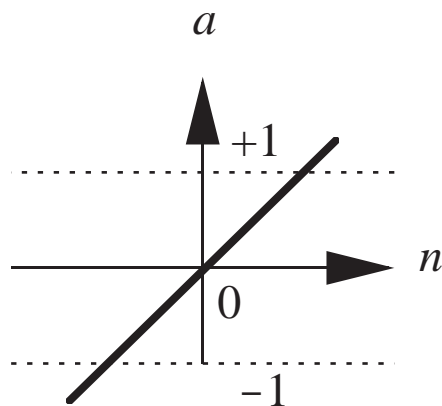
Single-Input *hardlim* Neuron

$$a = \text{purelin}(n)$$

Linear Transfer Function

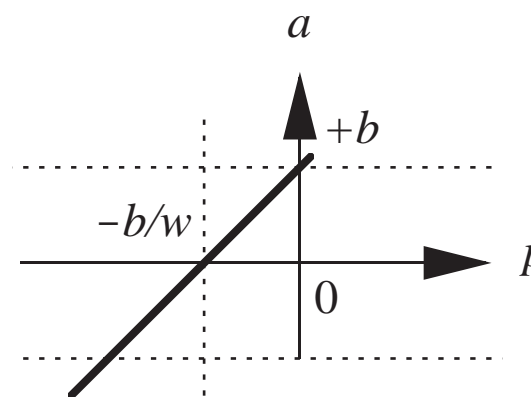

$$a = \text{purelin}(wp + b)$$

Single-Input *purelin* Neuron

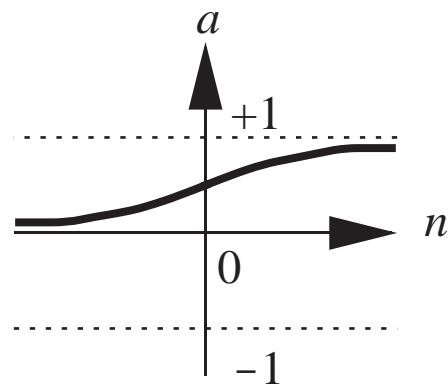

$$a = \text{logsig}(n)$$

Log-Sigmoid Transfer Function

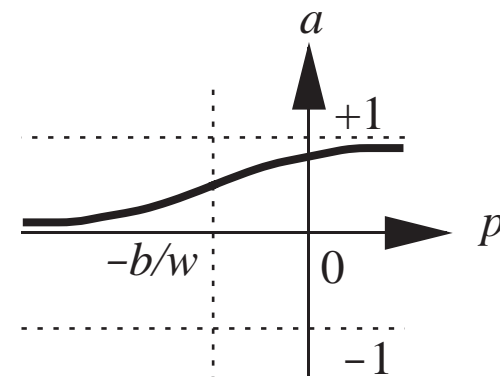

$$a = \text{logsig}(wp + b)$$

Single-Input *logsig* Neuron

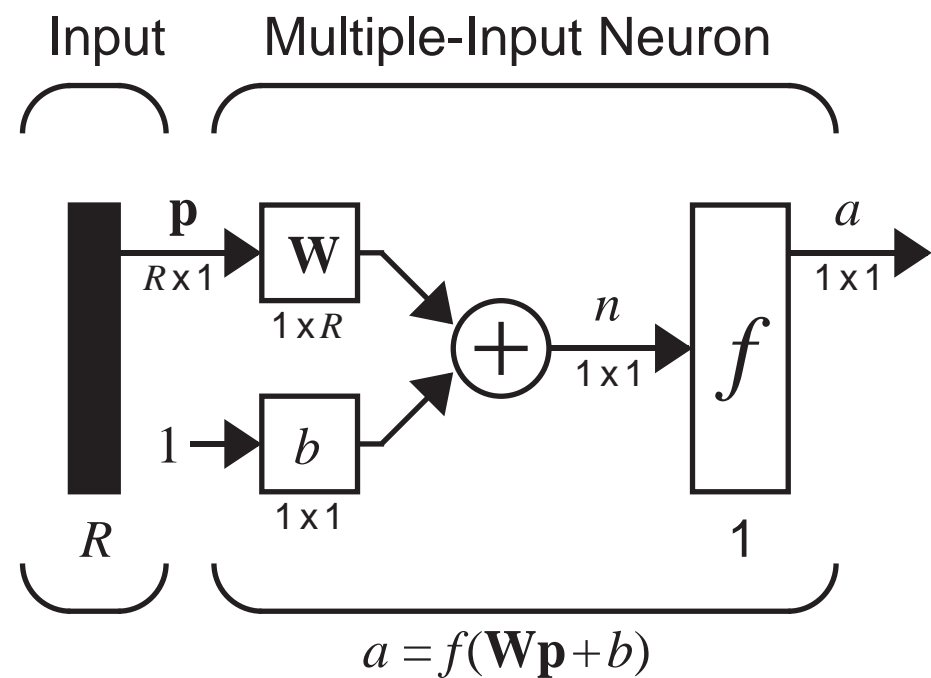
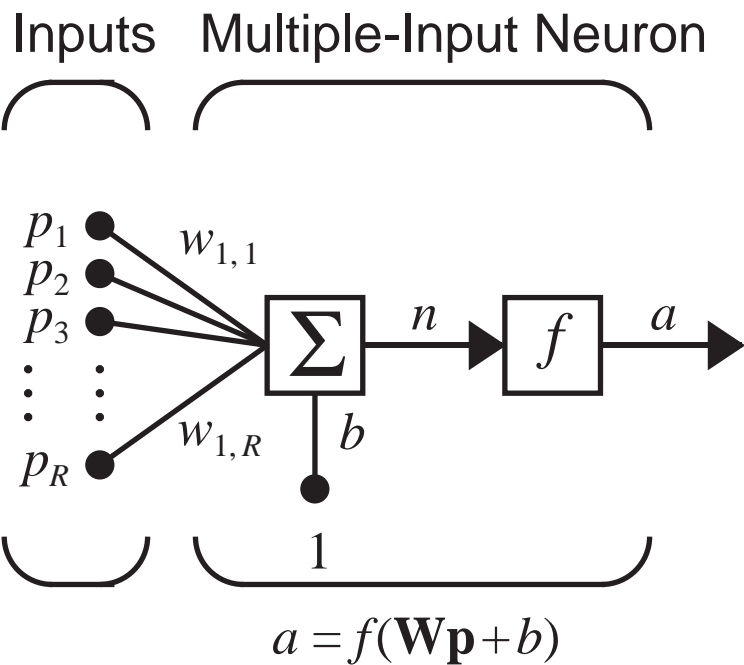

Abbreviated Notation

Layer of Neurons

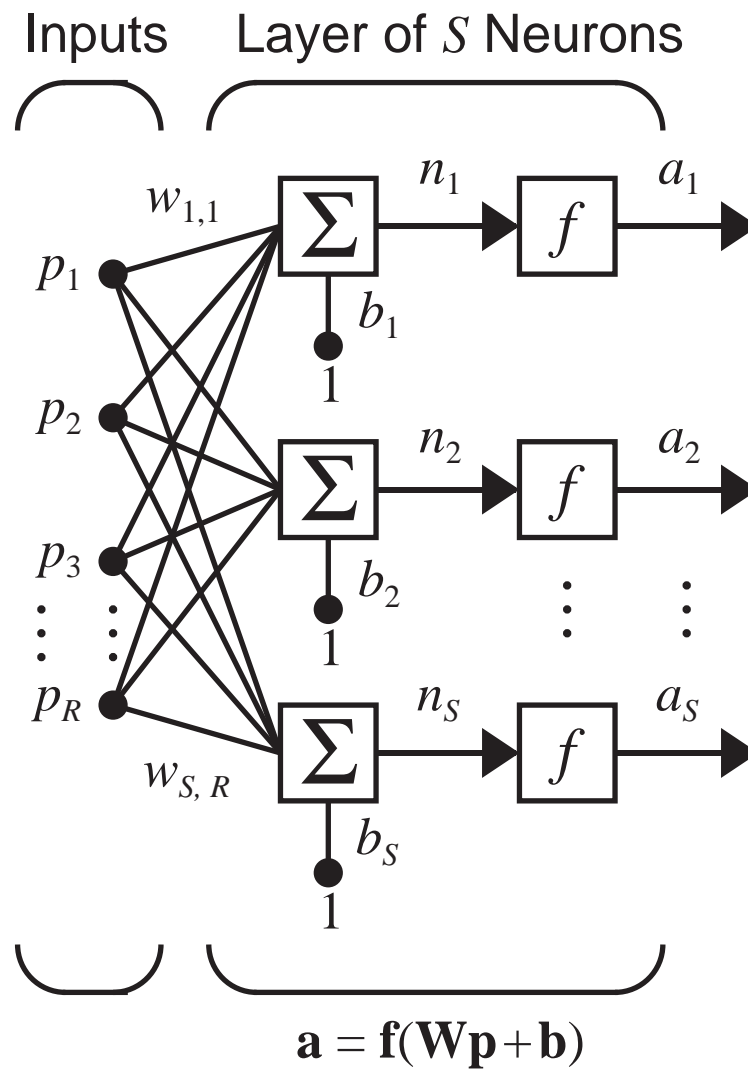

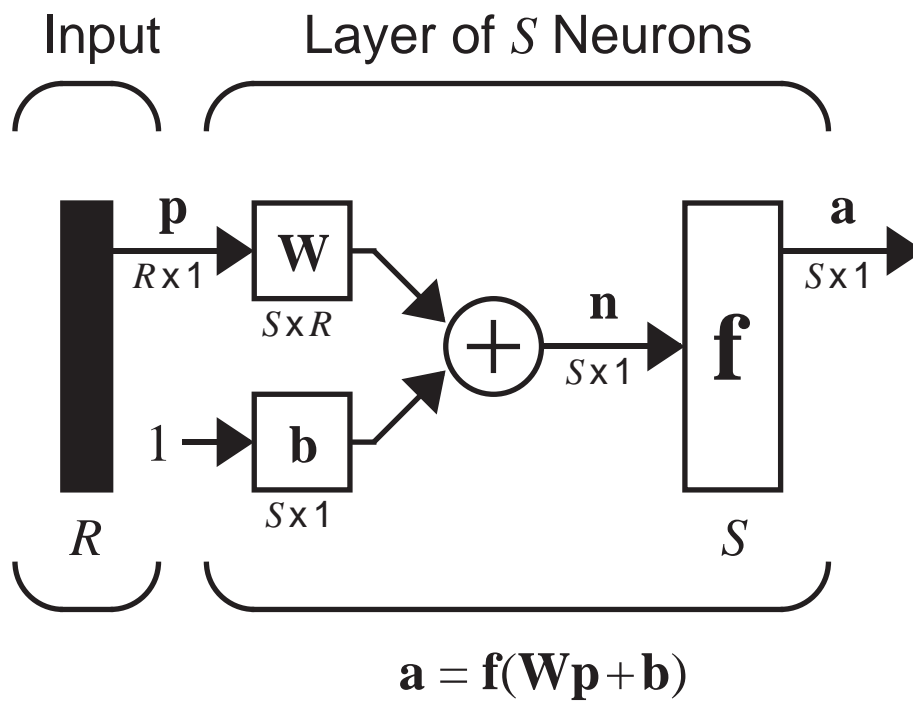

$$\mathbf{W} = \begin{bmatrix} w_{1,1} & w_{1,2} & \cdots & w_{1,R} \\ w_{2,1} & w_{2,2} & \cdots & w_{2,R} \\ \vdots & \vdots & & \vdots \\ w_{S,1} & w_{S,2} & \cdots & w_{S,R} \end{bmatrix}$$

$$\mathbf{p} = \begin{bmatrix} p_1 \\ p_2 \\ \vdots \\ p_R \end{bmatrix} \quad \mathbf{b} = \begin{bmatrix} b_1 \\ b_2 \\ \vdots \\ b_S \end{bmatrix} \quad \mathbf{a} = \begin{bmatrix} a_1 \\ a_2 \\ \vdots \\ a_S \end{bmatrix}$$

Multilayer Network

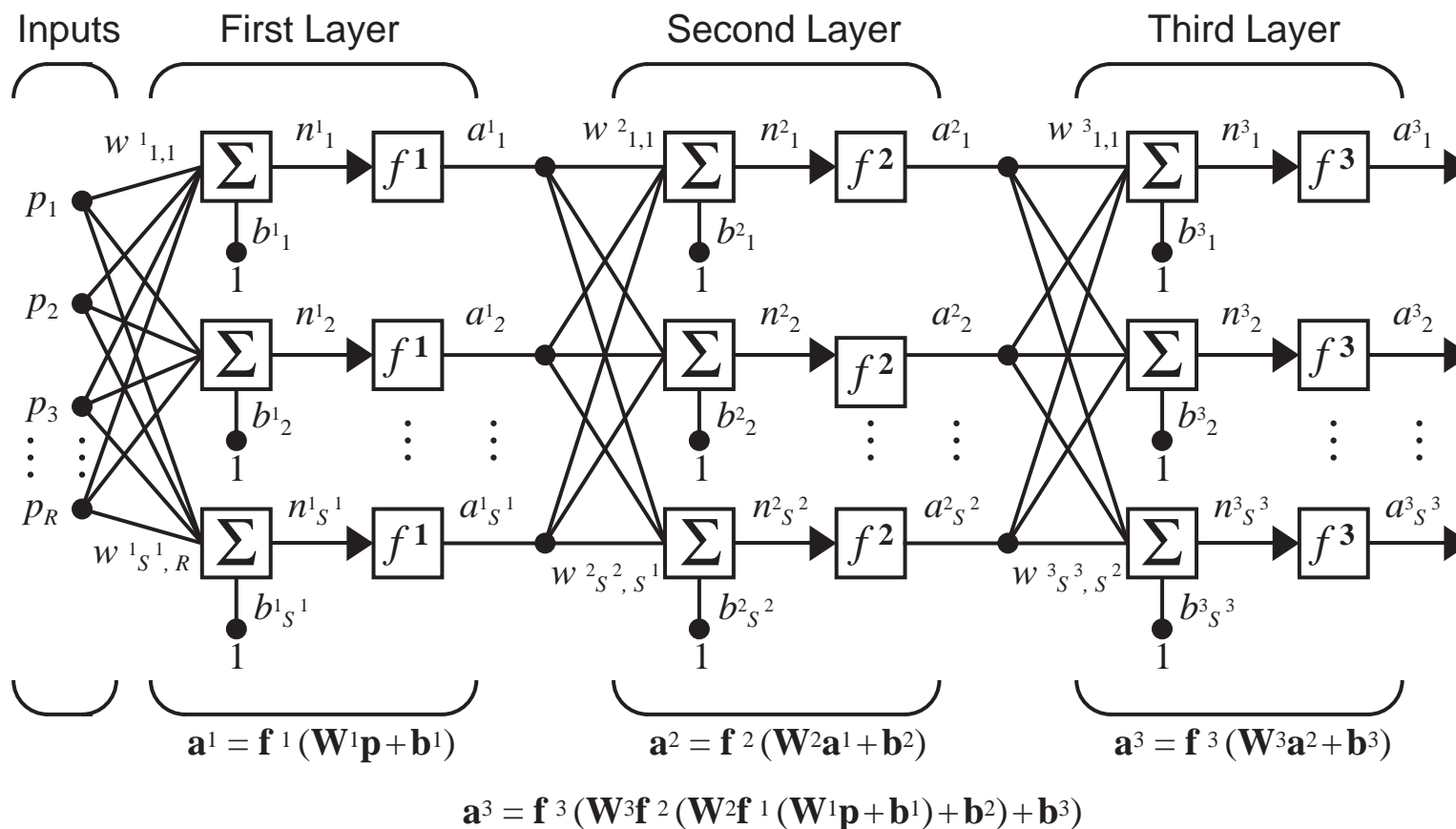

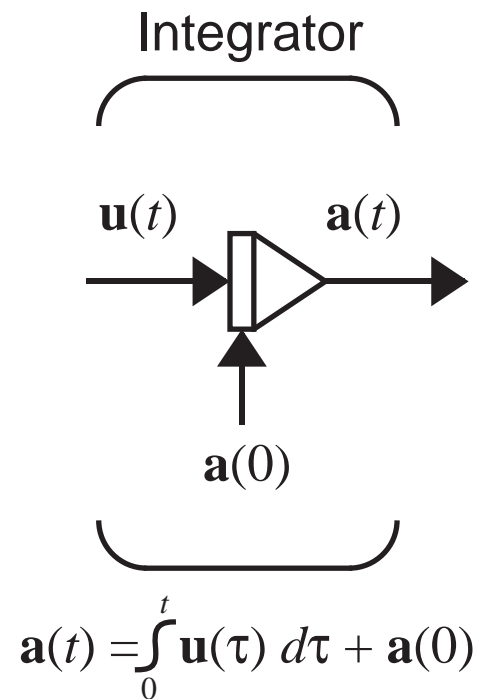
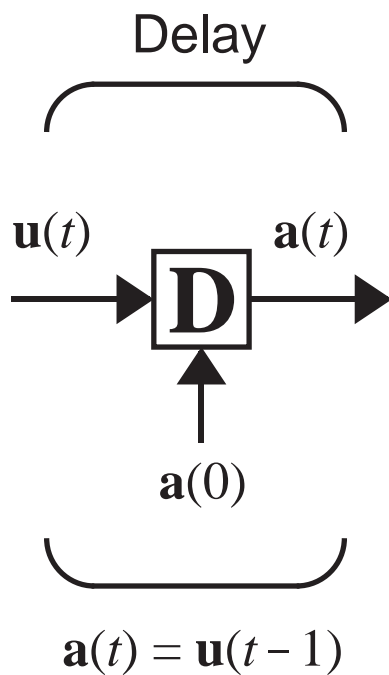

2

Recurrent Network

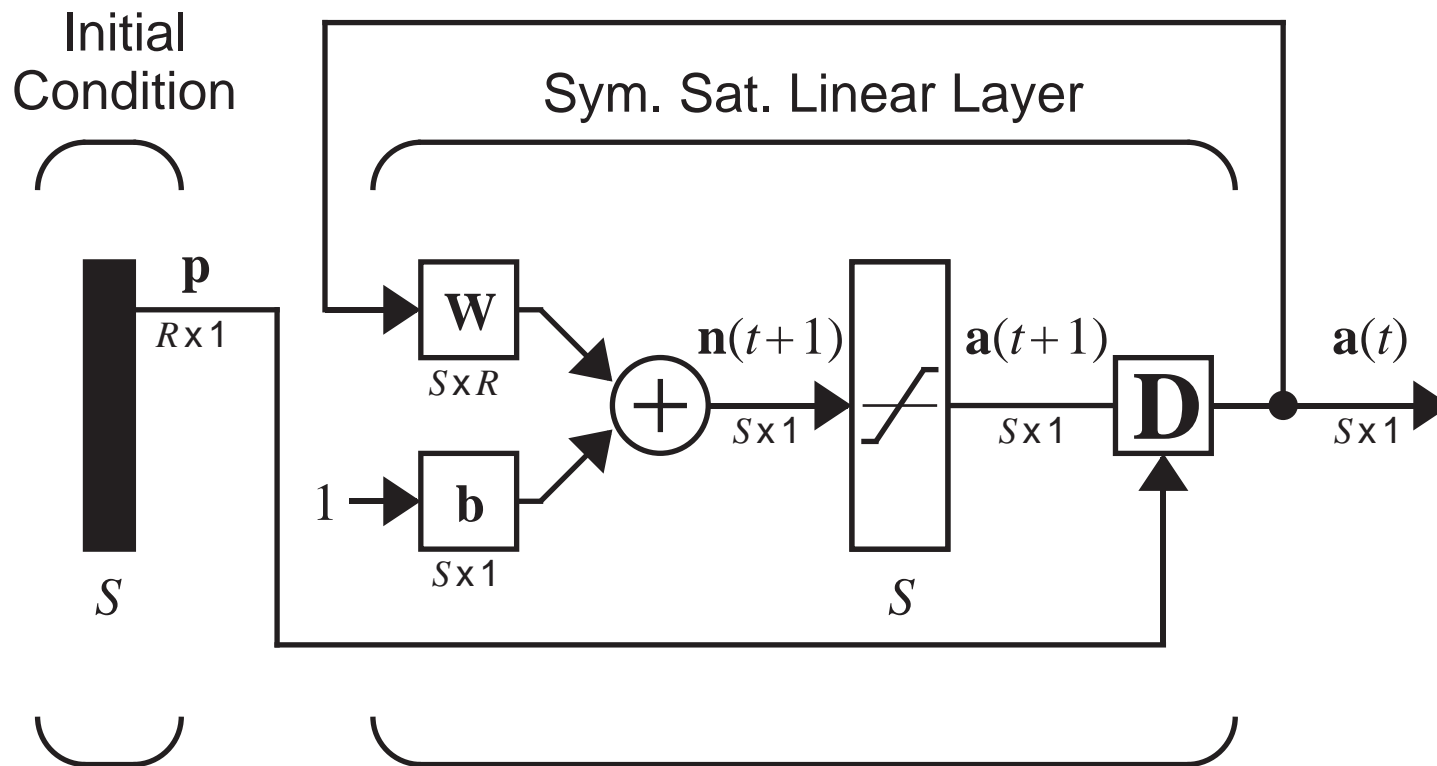

$$\mathbf{a}(0) = \mathbf{p} \quad \mathbf{a}(t+1) = \text{satlin}(\mathbf{W}\mathbf{a}(t) + \mathbf{b})$$

$$\mathbf{a}(1) = \text{satlins}(\mathbf{W}\mathbf{a}(0) + \mathbf{b}) = \text{satlins}(\mathbf{W}\mathbf{p} + \mathbf{b})$$

$$\mathbf{a}(2) = \text{satlins}(\mathbf{W}\mathbf{a}(1) + \mathbf{b})$$